



for Microplates –
Well Positions

Secretariat
Society for Biomolecular Screening

Contents

	Page
Foreword	3
1 Scope and purpose	4
1.1 Scope	4
1.2 Purpose	4
2 Normative references.....	4
3 Definitions	4
4 Well positions.....	4
4.1 96 well microplate	4
4.2 384 well microplate	5
4.3 1536 well microplate	6
Figure	8
Figure 1- Well positions of a 96 well microplate	8
Figure 2- Well positions of a 384 well microplate	9
Figure 3- Well positions of a 1536 well microplate	10
Annex	11
Annex A (Informative) Interpretation of Figures	11

Foreword

As early as the first meeting of the Society for Biomolecular Screening (SBS) in 1995, a need for clearly defined dimensional standards of a microplate was identified. At the time, the microplate was already becoming an essential tool used in drug discovery research. At the time, the concept of a microplate was similar among various manufacturers, but the dimensions of microplates produced by different vendors, and even within a single vendors catalog line varied. This often caused numerous problems when microplates were to be used in automated laboratory instrumentation.

In late 1995, members of the SBS began working on defining dimensional standards for the standard 96 well microplate. The first written proposal was released in December 1995 and presented at numerous scientific conferences and journals throughout 1996. This initial proposed standard was officially presented to the membership of SBS for approval at the annual meeting in October 1996 in Basel, Switzerland. Between then and late 1998, various versions of the proposed standards for 96 and 384 well microplates were circulated to the membership of the society. In early 1999, efforts to begin formalizing the proposed standards in preparation for submission to a recognized standards organization were begun. The email ListServ was started in March, and the first regular quarterly meeting of the working committee met in August of that year. To date, the ListServ contains members representing over 100 corporations, educational institutions, and government organizations from over 15 nations.

There is one annex in this standard. Annex A is informative and not considered part of this standard. It is provided as an aid only for the interpretation of specific elements of ASME Y14.5 as they apply to figures in SBS standards.

Suggestions for improvement of this standard will be welcome. They should be sent to the Microplate Standards Development Committee of the Society for Biomolecular Screening, 36 Tamarack Avenue, Suite 348, Danbury, CT 06811.

This standard was processed and approved for submittal to ANSI by the Microplate Standards Development Committee of the Society for Biomolecular Screening. Committee approval of this standard does not necessarily imply that all committee members voted for its approval. At the time it approved this standard, the committee had the following member organizations:

Marc Feiglin, Co-chair
Carol Homon, Co-chair

Organization Represented

Apogent Discoveries^{1,2}
BD Biosciences¹
Beckman Coulter^{1,2}
Boehringer-Ingelheim³
Co Bio Engineering³
Corning¹
Greiner BioOne¹
Hamilton Co²
Hoffman La Roche³

MatriCal¹
Merck & Co³
Millipore¹
MJ Research^{1,2}
Molecular Devices^{1,2}
REMP²
Tecan²
Thermo Electron²
Whatman¹

Interest groups

1. Manufacturers of microplates (n=10)
2. Manufacturers of instrumentation that utilizes microplates (n=8)
3. Users of microplates that do not fit in either of the previous categories (n=4)

1 Scope and purpose

1.1 Scope

This standard defines the well center positional requirements of a microplate as specified in American National Standards covering these microplates.

1.2 Purpose

It is the purpose of this standard to describe the minimal dimensions required of a microplate that is considered to meet the standards. This standard also outlines the conditions required for making necessary measurements. Unless otherwise specified, all dimensions are applicable at 20 degrees C (68 degrees F). Compensation may be made for measurements made at other temperatures.

2 Normative references

The following standards contain provisions which, through reference in this text, constitute provisions of this American National Standard. At the time of publication, the editions indicated were valid. All standards are subject to revision, and parties to agreements based on this American National Standard are encouraged to investigate the possibility of applying the most recent editions of the standards listed below. ASME Y14.5M-1994, *Dimensioning and Tolerancing*

3 Definitions

There are many terms and definitions associated with microplates that have special meaning to the industry. The following are definitions of terms used in this document:

3.1 ASME: Abbreviation for the American Society of Mechanical Engineers

3.2 ANSI: Abbreviation for the American National Standards Institute, Inc.

3.3 SBS: Abbreviation for the Society for Biomolecular Screening.

4 Well positions

Microplates that meet this standard may either comply with those standards specified in parts 4.1, 4.2, or 4.3. Microplates, or instruments that use them, that advertise compliance with this standard must clearly state which of these three parts they meet.

4.1 96 well microplate

4.1.1 Well layout

4.1.1.1 The wells in a 96 well microplate should be arranged as eight rows by twelve columns.

4.1.2 Well column position

4.1.2.1 The distance between the left outside edge of the plate and the center of the first column of wells shall be 14.38 mm (0.5661 inches)

4.1.2.2 The left edge of the part will be defined as the two 12.7 mm areas (as measured from the corners) as specified in SBS-1

4.1.2.3 Each following column shall be an additional 9. mm (0.3543 inches) in distance from the left outside edge of the plate.

4.1.3 Well row position

4.1.3.1 The distance between the top outside edge of the plate and the center of the first row of wells shall be 11.24 mm (0.4425 inches)

4.1.3.2 The top edge of the part will be defined as the two 12.7 mm areas (as measured from the corners) as specified in SBS-1

4.1.3.3 Each following row shall be an additional 9. mm (0.3543 inches) in distance from the top outside edge of the plate.

4.1.4 Positional Tolerance

4.1.4.1 The positional tolerance of the well centers will be specified using so called "True Position". The center of each well will be within a 0.70 mm (0.0276 inches) diameter of the specified location. This tolerance will apply at "RFS" (regardless of feature size).

4.1.5 Well Markings

4.1.5.1 The top left well of the plate shall be marked in a distinguishing manner. Such distinguishing marks include, but are not limited to the following:

- The top left well of the plate can be marked with the letter A or numeral 1 located on the left-hand side of the well.
- The top left well of the plate can be marked with a numeral 1 located on the upper side of the well.

4.1.5.2 Additional markings may be provided.

4.2 384 well microplate

4.2.1 Well layout

4.2.1.1 The wells in a 384 well microplate should be arranged as sixteen rows by twenty-four columns.

4.2.2 Well column position

4.2.2.1 The distance between the left outside edge of the plate and the center of the first column of wells shall be 12.13 mm (0.4776 inches)

4.2.2.2 The left edge of the part will be defined as the two 12.7 mm areas (as measured from the corners) as specified in SBS-1

4.2.2.3 Each following column shall be an additional 4.5 mm (0.1772 inches) in distance from the left outside edge of the plate.

4.2.3 Well row position

4.2.3.1 The distance between the top outside edge of the plate and the center of the first row of wells shall be 8.99 mm (0.3539 inches)

4.2.3.2 The top edge of the part will be defined as the two 12.7 mm areas (as measured from the corners) as specified in SBS-1

4.2.3.3 Each following row shall be an additional 4.5 mm (0.1772 inches) in distance from the top outside edge of the plate.

4.2.4 Positional Tolerance

4.2.4.1 The positional tolerance of the well centers will be specified using so called “True Position”. The center of each well will be within a 0.70 mm (0.0276 inches) diameter of the specified location. This tolerance will apply at “RFS” (regardless of feature size).

4.2.5 Well Markings

4.2.5.1 The top left well of the plate shall be marked in a distinguishing manner. Such distinguishing marks include, but are not limited to the following:

- The top left well of the plate can be marked with the letter A or numeral 1 located on the left-hand side of the well.
- The top left well of the plate can be marked with a numeral 1 located on the upper side of the well.

4.2.5.2 Additional markings may be provided.

4.3 1536 well microplate

4.3.1 Well layout

4.3.1.1 The wells in a 1536 well microplate should be arranged as thirty-two rows by forty-eight columns.

4.3.2 Well column position

4.3.2.1 The distance between the left outside edge of the plate and the center of the first column of wells shall be 11.005 mm (0.4333 inches)

4.3.2.2 The left edge of the part will be defined as the two 12.7 mm areas (as measured from the corners) as specified in SBS-1

4.3.2.3 Each following column shall be an additional 2.25 mm (0.0886 inches) in distance from the left outside edge of the plate.

4.3.3 Well row position

4.3.3.1 The distance between the top outside edge of the plate and the center of the first row of wells shall be 7.865 mm (0.3096 inches)

4.3.3.2 The top edge of the part will be defined as the two 12.7 mm areas (as measured from the corners) as specified in SBS-1

4.3.3.3 Each following row shall be an additional 2.25 mm (0.0886 inches) in distance from the top outside edge of the plate.

4.3.4 Positional Tolerance

4.3.4.1 The positional tolerance of the well centers will be specified using so called “True Position”. The center of each well will be within a 0.50 mm (0.0197 inches) diameter of the specified location. This tolerance will apply at “RFS” (regardless of feature size).

4.3.5 Well Markings

4.3.5.1 The top left well of the plate shall be marked in a distinguishing manner. Such distinguishing marks include, but are not limited to the following:

- The top left well of the plate can be marked with the letter A or numeral 1 located on the left-hand side of the well.
- The top left well of the plate can be marked with a numeral 1 located on the upper side of the well.

4.3.5.2 Additional markings may be provided.

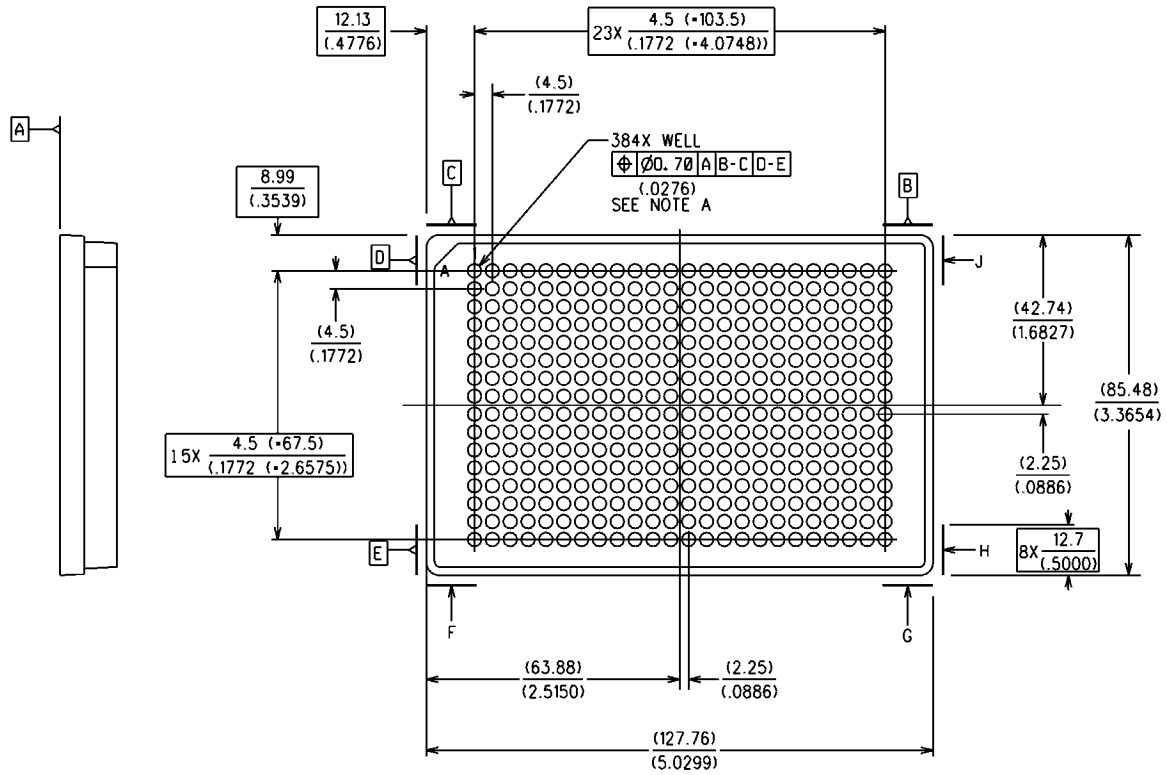

NOTES:

- 1 The drawing standard used is ASME Y14.5M-1994
 - 2 The geometry shown is for illustration only and does not imply any preferred or required construction.
 - 3 Dimensions shown are: Millimeters / (Inches)
 - 4 Dimensions and tolerances do not include draft.
- A The top left well of the plate shall be clearly marked (e.g.: on the left with the letter "A" or the numeral "1", or at the top with the numeral "1"). Additional markings may be provided.

Figure 2- Well positions of a 384 well microplate

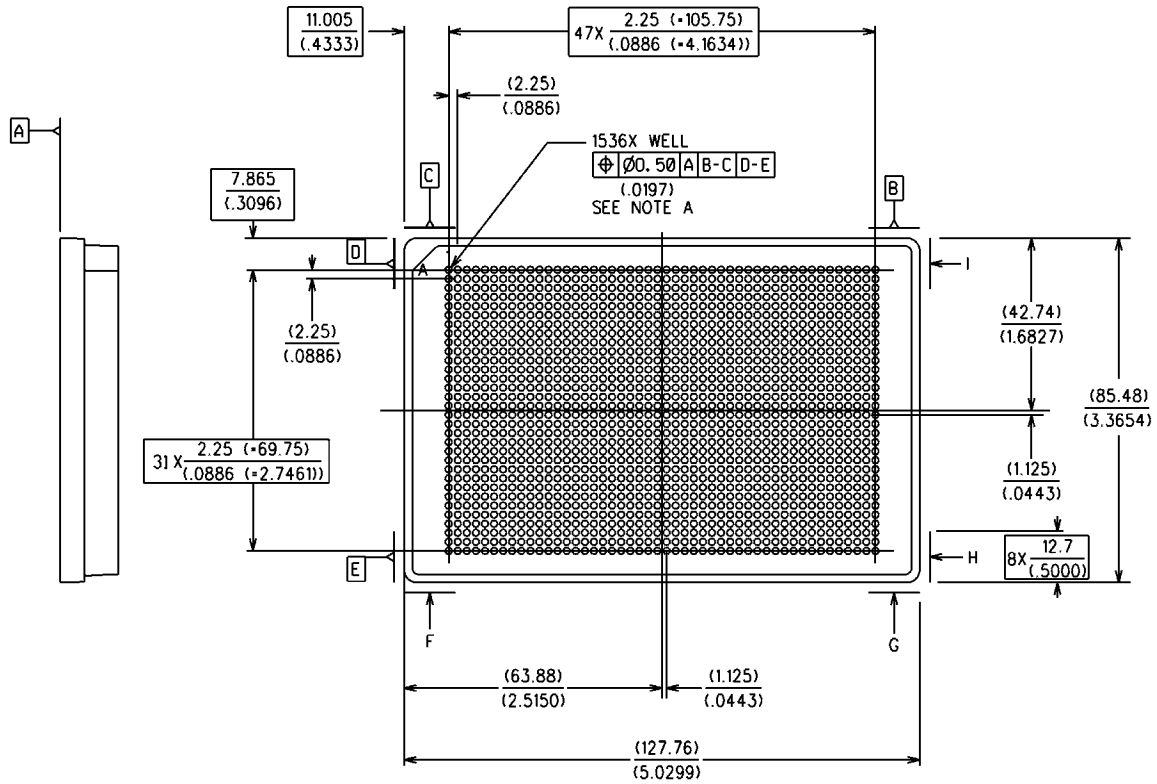

NOTES:

- 1 The drawing standard used is ASME Y14.5M-1994
 - 2 The geometry shown is for illustration only and does not imply any preferred or required construction.
 - 3 Dimensions shown are: Millimeters / (Inches)
 - 4 Dimensions and tolerances do not include draft.
- A The top left well of the plate shall be clearly marked (e.g.: on the left with the letter "A" or the numeral "1", or at the top with the numeral "1"). Additional markings may be provided.

Figure 3- Well positions of a 1536 well microplate

Annex

Annex A (Informative) Interpretation of Figures

Annex A is a general guide to interpreting figures in SBS standards in accordance with ASME Y14.5M-1994. Annex A is not intended to be a substitute for a working knowledge of dimensioning and tolerancing practices contained therein. The specific examples in Annex A are not comprehensive and may or may not apply to the figures in this particular SBS standard.

THIS ON THE DRAWING:

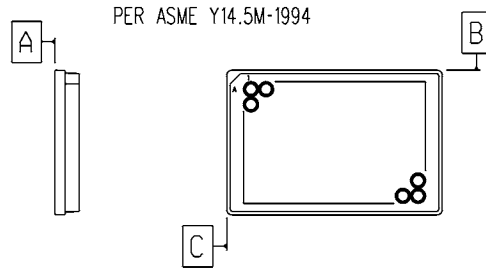

MEANS THIS:

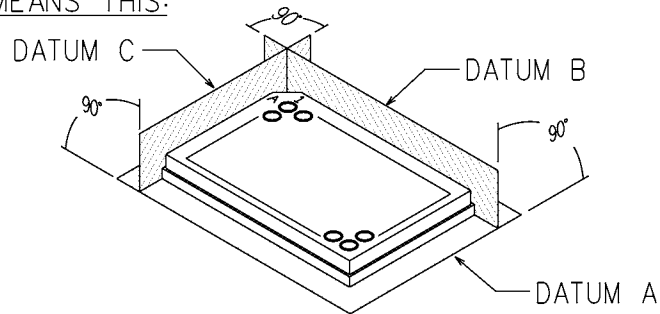

A.1 Specifying datum

THIS ON THE DRAWING:

PER ASME Y14.5M-1994 PARAGRAPH 1.7.3, 4.5.10, 6.3.1.2

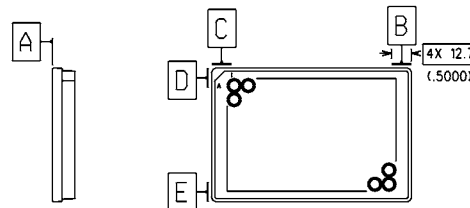

MEANS THIS:

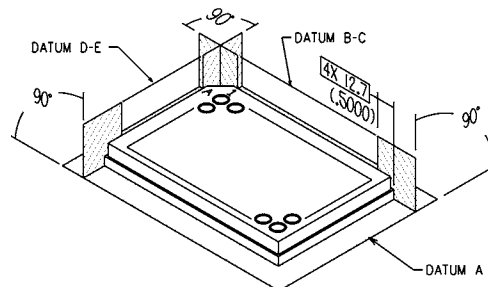

A.2 Specifying composite datum

THIS ON THE DRAWING:

PER ASME Y14.5M-1994
 PARAGRAPH 1.7.3, 4.5.10, 4.5.7.1

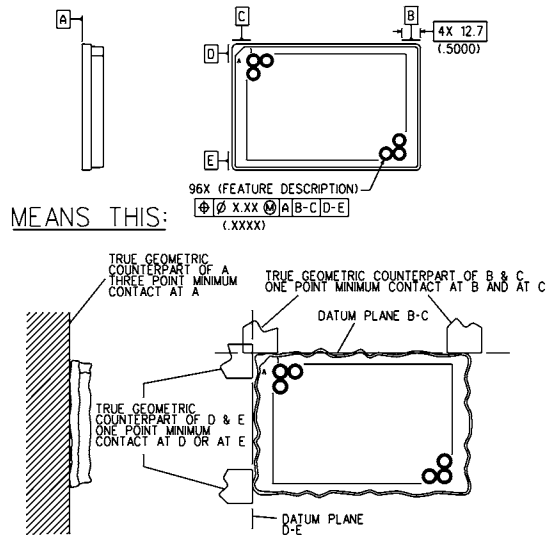

A.3 Application of composite datum

THIS ON THE DRAWING:

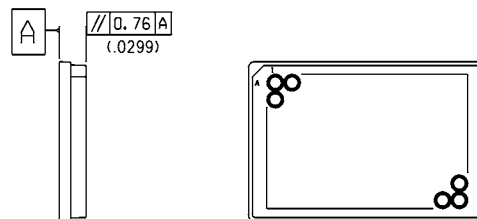

MEANS THIS: PER ASME Y14.5M-1994 PARAGRAPH 6.6.3.1

CONTROLLED SURFACE MUST LAY WITHIN A 0.76MM \pm (.0299 INCH) WIDE TOLERANCE ZONE, PARALLEL WITH DATUM A, AND MUST NOT EXCEED LIMITS OF SIZE

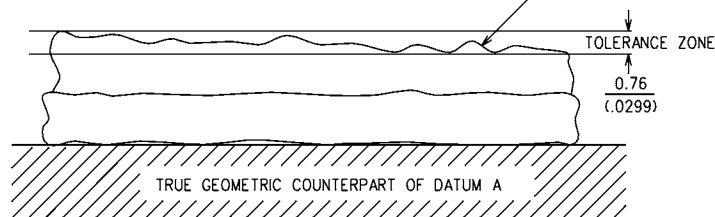

A.4 Parallelism

THIS ON THE DRAWING:

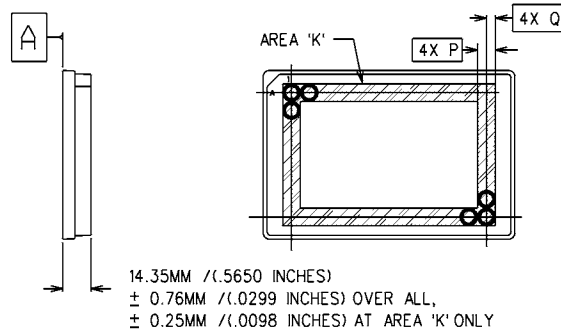

MEANS THIS:

PER ASME Y14.5M-1994 PARAGRAPH 1.7.3
 (STEP ALLOWED PER SBS-2 SHOWN FOR CLARITY)

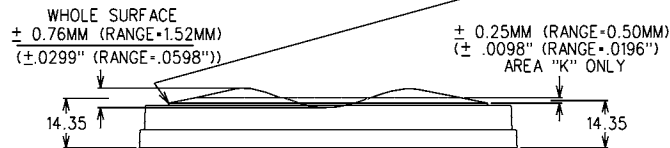

A.5 Tolerances over a limited area

PER ASME Y14.5M-1994
 PARAGRAPH 5.3.2.1

TRUE POSITION vs ± TOLERANCE

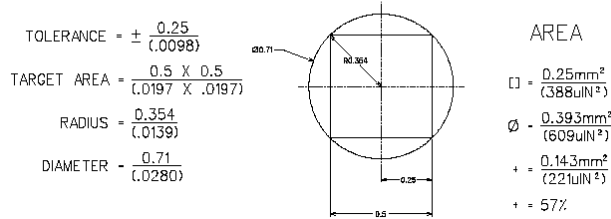

PER ASME Y14.5M-1994
 PARAGRAPH 3.4.3

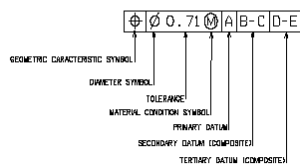

PER ASME Y14.5M-1994
 PARAGRAPH 3.3.2

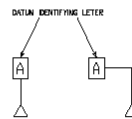

A.6 True position vs ± tolerance